

2007-2008 *Hydrogen Student Design Contest*

*Wayne State University*

*Blue Sky*

*Energy Solutions*

*Cleaning the Air You Fly In*



Team 3 Members:

Danton Garcia, Jan-Michael Statchura, Yuriy Kaninov, Samantha Staley,  
Ashraf Mustafa, Tim O'Meara, Will Hotchkiss

Faculty Advisor: Dr. Monier Botros, PhD, P.E.

## 1.0 Executive Summary

As airports expand their operations to accommodate more travelers, concerns about adverse effects on the environment have grown. Both airplanes and ground vehicles generate high levels of noise and emit measurable levels of Carbon Dioxide (CO<sub>2</sub>), Nitrogen Oxides (NO<sub>x</sub>), and other volatile gases into the atmosphere. The objective of this proposal is to introduce hydrogen technologies at Columbia Airport (CAE) in South Carolina that can be available by 2009, to address the airport needs. These needs include the reduction of harmful air pollution, noise pollution, and water contamination while also optimizing the efficiency of the energy used. The Federal Aviation Administration created the Voluntary Airport Low Emissions Program which gives financial support to airports that implement alternative fuels, and hence, the implementation of alternative fuel dispensing had a high priority in the design process.

Blue Sky Energy Solutions from Wayne State University in Detroit, Michigan considered three designs. After a thorough technical and cost analysis, the most effective approach was found to incorporate hydrogen production with dispensing and power producing capabilities. The system uses natural gas and water to produce hydrogen via an auto-thermal reformer; the HyRadix Adeo 100 which requires 30 kW of electrical power and produces 216 kg of hydrogen per day. The hydrogen is used to fuel three Proton Exchange Membrane (PEM) fuel cells to produce 150 kW of three phase electrical power. Hydrogen is blended with natural gas and dispensed as alternative fuel, Hythane<sup>®</sup>, to six vehicles. The conversion of six vehicles to use Hythane<sup>®</sup> with a growth opportunity to add fourteen vehicles in two years is included. Detailed thermodynamics, electrical, and environmental analysis are used to verify the design.

Though airplanes emit harmful gases and noise, they are not directly controlled by the airport. On the other hand, the airport owns and operates many gasoline fueled vehicles. Because the hydrogen economy is not currently economical, Hythane<sup>®</sup> is used as a fuel to “bridge the gap” between the fossil fuels of today and the hydrogen of tomorrow. A reduction of at least 50% NO<sub>x</sub> and 7% CO<sub>2</sub> can be expected with a blend of only 3% of hydrogen by mass. This, along with the use of PEM fuel cells, will reduce CO<sub>2</sub> emissions at CAE by 125 tons per year. To reduce noise at CAE, airlines will be encouraged to use electric ground support equipment. For that purpose a *SuperCharge*<sup>™</sup> GSE-200DP unit specifically designed to charge airline ground support equipment will be installed.

Safety was a paramount concern in the design of this system. A complete Failure Mode and Effect Analysis and system simulation using LabView software were performed. The system simulation was used to determine how sub-systems interacted and the possible failures that could occur. The system is designed with several control features to prevent major failure modes.

The capital cost of the system is \$2.7 million, which satisfies the \$3.0 million budget limit. \$400 per day is needed to run the HyRadix reformer. A fuel savings of at least \$5 per vehicle per day will be seen once converted to Hythane<sup>®</sup>. Blue Sky expects for airlines and shuttle services to be required to convert to alternative fuels as emissions standards increase. For this reason, Hythane<sup>®</sup> can be sold to companies with vehicle fleets. If 500 kg/day is sold, CAE can expect to experience a 7% internal rate of return after 10 years when the fuel is sold for \$4.5/kg. A marketing campaign to promote the benefits of Hythane<sup>®</sup> and to educate the public of the value of clean air will cost \$50,000.

# Table of Contents

1.0	Executive Summary .....	2
	Table of Contents .....	3
2.0	Technical Design .....	6
2.1	Design Selection.....	6
2.2	System Adaptability - Hydrogen Feedstock.....	7
2.3	System Location.....	7
2.4	System Overview .....	7
2.4.1	Vehicle Refueling Sub-System.....	9
2.4.2	Proton Exchange Membrane Fuel Cell Sub-System.....	10
2.5	Major System Components .....	10
2.5.1	Auto Thermal Reformer.....	10
2.5.2	Hythane <sup>®</sup> Blender .....	11
2.5.3	Water De-Ionizer .....	11
2.5.4	Water Cooling Tower .....	11
2.5.5	Compressors.....	11
2.5.5.1	Compressor One – Natural Gas .....	12
2.5.5.2	Compressor Two – Hydrogen.....	12
2.5.5.3	Compressor Three – Hythane <sup>®</sup> .....	12
2.5.6	Hydrogen Storage Buffer .....	13
2.6	Dispensing System .....	14
2.6.1	Dispensing unit .....	14
2.6.2	Cascade storage tanks.....	14
2.7	Electrical Requirements .....	16
2.7.1	Selection of Transformers .....	16
2.8	System Daily Use.....	17
3.0	Safety Analysis .....	18
3.1	Introduction .....	18
3.2	Design Safety .....	18
3.2.1	Storage Tanks.....	18
3.2.2	Piping, Tubing, and Fittings.....	18
3.2.3	Location and Construction.....	18
3.3	Process Safety .....	18
3.3.1	Manual Emergency Shut-Down.....	18
3.3.2	Valves .....	18

3.3.3	Gas Detection and Fire Suppression .....	19
3.3.4	Programmable Logic Control (PLC) .....	19
3.4	Major Failure Modes .....	19
3.5	System Analysis Simulation .....	20
4.0	Economic Analysis .....	21
4.1	Capital Costs .....	21
4.2	Operational Costs .....	21
4.3	Voluntary Airport Low Emissions Program .....	23
4.4	Maintenance Cost .....	24
4.5	System Outlook .....	24
4.6	Hydrogen Production Site Overall and Future Value Added .....	24
5.0	Environmental Analysis .....	25
5.1	Air Quality .....	25
5.1.1	CO <sub>2</sub> Analysis .....	25
5.1.2	NO <sub>x</sub> Analysis .....	26
5.1.3	Hythane <sup>®</sup> Vehicle Case Study .....	27
5.2	Noise Reduction .....	27
5.3	Water Quality .....	28
5.4	Energy Efficiency .....	28
6.0	Marketing and Education .....	29
6.1	Implementation .....	29
6.1.1	CAE Traveler Questionnaire .....	29
6.1.2	On-site Marketing and Education .....	29
6.1.2.1	Shuttle Bus Marketing .....	29
6.1.3	Off-site Marketing and Education .....	30
6.2	Future Commitment .....	30
6.3	Project Management .....	30
Appendix	.....	32
References	.....	37

## List of Figures and Tables

Figure 1: System Location .....	7
Figure 2: System Process Schematic .....	8
Figure 3 Process Schematic .....	9
Figure 4: Daily Power Production and Consumption .....	17
Figure 5: User Interface for System Simulation .....	20
Figure 6: Example of Simulation of Failure Mode .....	20
Figure 7: Cost of Hythane with Varying Natural Gas Prices Compared to Gasoline Cost .....	23
Figure 8: Emissions Reductions on a Ford F-150.....	27
Table 1: Decision Matrix .....	6
Table 2: Assumptions for Fuel Requirements .....	9
Table 3: General Adeo Specifications .....	10
Table 4: Natural Gas Compressor Requirements.....	12
Table 7: Equilibrium Tank Pressures.....	13
Table 5: Hythane Compressor Requirement.....	13
Table 6: Compressor Specifications .....	13
Table 8: Pressure Ratio for Each Tank .....	15
Table 9: Major Sub-System Failure Modes .....	19
Table 10: System Capital Costs .....	21
Table 11: Personnel Rates.....	22
Table 12: Utility Rates .....	22
Table 13: Operating Costs .....	22
Table 14: Total Savings per Day per Vehicle Using Hythane.....	23
Table 15: Expected Maintenance.....	24
Table 16: Net Income/Savings.....	24
Table 17: Values Added From Design.....	24
Table 18: Breakdown of South Carolina Electrical Power Grid Sources <sup>(11)</sup> .....	25
Table 19: CO2 Emissions for Each Source <sup>(10)</sup> .....	25
Table 20: Net Reduction in Carbon Dioxide .....	26
Table 21: Go Zero Carbon Dioxide Sequestering Program Effects <sup>(13)</sup> .....	26
Table 22 Summary of Emissions Reductions Experienced by Blended Fuel <sup>(30)</sup> .....	27
Table 23: Energy Efficiency .....	28

## 2.0 Technical Design

### 2.1 Design Selection

To meet the needs of Columbia Airport (CAE), three hydrogen systems were analyzed. These systems were designed to reduce emissions, water pollution, and noise pollution while increasing energy efficiency. The objective of each system is described below:

- 1) To produce maximum power output, utilizing a solid oxide fuel cell and gas turbine generator.
- 2) To produce electric power and dispense Hythane<sup>®</sup> via a natural gas auto thermal reformer.
- 3) To produce electric power and dispense Hydrogen by utilizing solar energy for electrolysis

Design two was chosen as the best design since it had the highest impact on the customer needs. System two utilizes natural gas to produce hydrogen for the production of electricity and the formation of Hythane<sup>®</sup>. System one was capable of producing approximately 1.5 MW of electric power at an extremely efficient level but did not have enough impact on the environment directly related to the airport. It was also determined that design one did not produce or utilize hydrogen with enough visibility for the purposes of the hydrogen contest. The use of electrolysis in design three proved to be inefficient and more costly for grid power usage.

CAE's needs were weighted and compared, as shown in Table 1, to determine which system would provide the best solution. The numbers on the horizontal axis represented the importance to CAE while the numbers on the vertical axis represented the designs ability to fulfill the criteria in the center. The numbers were then multiplied and summed to give the total design score.

<b>Rating of Importance to Customer</b>	<b>10</b>	<b>9</b>	<b>5</b>	<b>10</b>	
<b>4</b>	Significant air improvement	Eliminated waste in water stream	< 30 dBA	> 70%	
<b>3</b>	Moderate air improvement	Reduced waste in water stream	40 > x < 50 dBA	40 < x < 70%	
<b>2</b>	Slight air improvement	No negative effect	60 > x < 80 dBA	< 40%	
<b>1</b>	No negative effect	Increase waste in water stream	90 > x < 110 dBA	No negative effect	
<b>Design</b>	<b>Air Quality</b>	<b>Water Quality</b>	<b>Noise Pollution</b>	<b>Energy Efficiency</b>	<b>Total</b>
Design 1	2	1	1	4	<b>74</b>
Design 2	4	2	2	3	<b>98</b>
Design 3	4	2	3	2	<b>93</b>

**Table 1: Decision Matrix**



feasible. Due to its modular design, the system will meet the current needs of the airport with the ability of expanding to meet future needs. This can be done with the addition of a reformer, 50 kW fuel cells and storage tanks in parallel to the existing infrastructure. The customer can opt to remove the electrical power production sub-system and expand dispensing capabilities if it better suits the airport's needs. The proposed design is summarized in Table 2 and Figure 1 below.

Hydrogen Production	
Feedstock – rate	Natural Gas - 35.3 kg/h
Hydrogen Produced Per Day	216 kg
Hydrogen Storage Pressure	6500 kPa
Hythane <sup>®</sup> Dispensing	
Amount of Hythane <sup>®</sup> Capacity Per Vehicle	16.8 kg
Number of Vehicles Converted	6
Hythane <sup>®</sup> Storage Tank Pressures	5 MPa, 14 MPa, 30 MPa
Fuel Cells	
Type (Quantity)	PEM (3)
Amount of Electrical Power Produced	150 kW
Hydrogen Storage Pressure	6500 kPa
Hydrogen Flow Rate Required	8.7 kg/h

**Table 2: Summary of Sub-Systems**

Below is a schematic of the system.

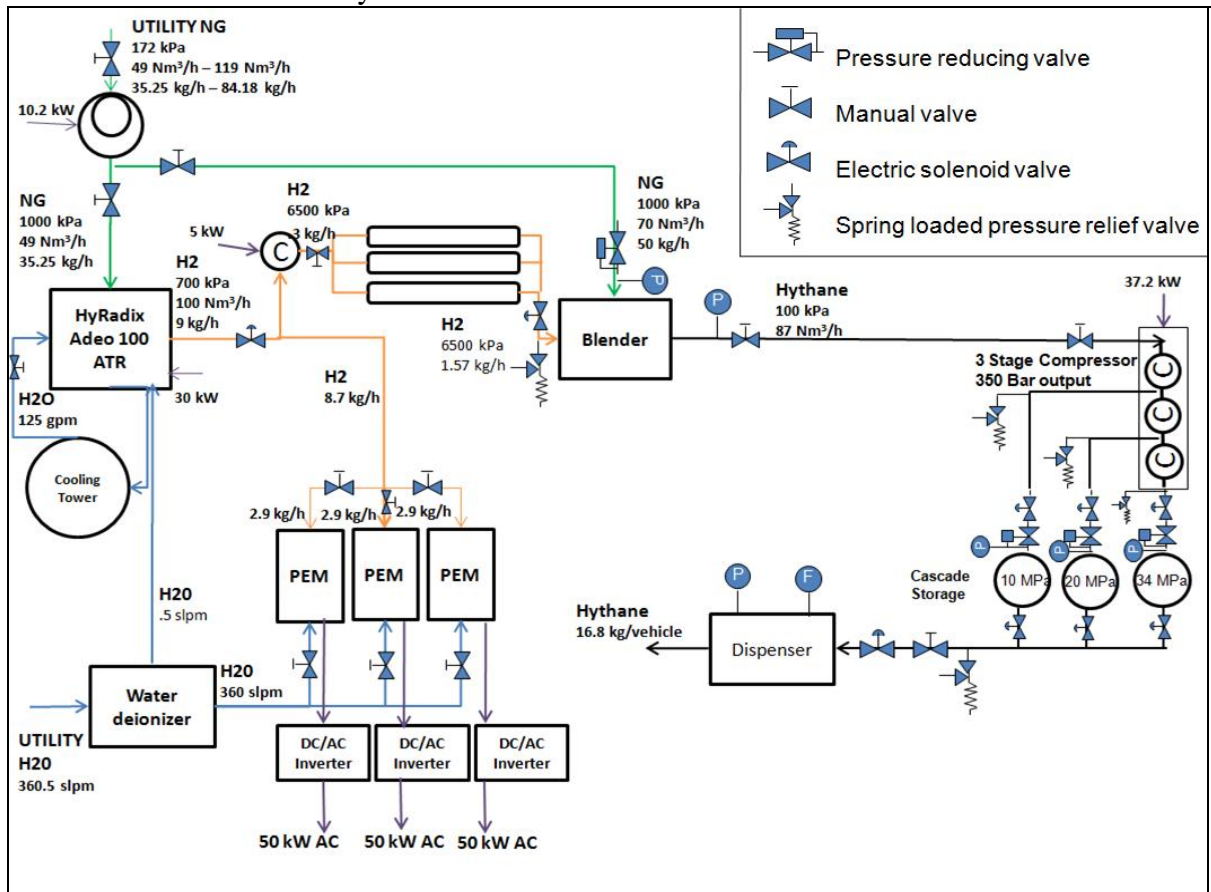

**Figure 2: System Process Schematic**

### 2.4.1 Vehicle Refueling Sub-System

To “bridge the gap” to the hydrogen economy, Hythane<sup>®</sup>, was selected in this design as a fuel alternative for use in CAE’s fleet vehicles. Hythane<sup>®</sup> is a patented blend of hydrogen and methane at a 20:80 ratio by volume, 3:97 ratio by mass, and a 7:93 ratio by energy<sup>(7)</sup>. The hydrogen concentration of this fuel provides a significant reduction in emissions. Because of its high methane content, the fuel can be used in a compressed natural gas (CNG) vehicle which is already a mature technology. The vehicle conversion is much more economical than fuel cell vehicles or conversion to hydrogen internal combustion engines. An engine software calibration is needed to realize the emissions reduction offered by this blended fuel. According to Dave Egan of Hythane Corporation, he noted that the implementation of Hythane<sup>®</sup> into the Columbia Airport will achieve goals set by the *Fuel Cell Challenge* in the following ways:

- Explore fueling options for fleets and personal use
- Explore on-site power stations
- R&D to refine the technologies- validate performance
- Raise public awareness
- Establish basis for codes and standards, siting and safety
- Put in place public policies to foster sufficient public and private investments
- Lower cost of H<sub>2</sub> by blending with CNG

Because Hythane<sup>®</sup> is a blend of two different substances; the analysis for the dispensing and storage requirements is more complicated. To understand fueling requirements, a spreadsheet analysis was done based on the assumptions listed in the Table 2.

Vehicle to be Converted	Full-sized gasoline powered truck
Number of Vehicles Converted	6
Average Driving Speed	20 miles/hour
City Fuel Economy	13 miles/gallon
Idle Time	30%

**Table 2: Assumptions for Fuel Requirements**

In addition to these assumptions, properties for gasoline, hydrogen, and methane were determined at a specified temperature (27°C) and pressure. Also, it is known that vehicles that run on Hythane<sup>®</sup> use onboard storage tanks at 25MPa (3600 psig). These vehicles, according to the work order from *ATW Automotive* for the conversion of vehicles from gasoline to compressed natural gas, switch operations to gasoline at 1 MPa (150 psig) tank pressure.

Based on the assumptions listed in Table 2 and the fuel properties, the required amount of fuel energy per was determined. First, it was calculated that 4.4 gallons of gasoline are required per vehicle per days. This was converted to an energy requirement of 521.2 MJ using the lower heating value of gasoline. Next, using the 110 L vehicle storage available for Hythane<sup>®</sup> (as per the *ATW Automotive* work order) and the blended fuel density, the total available storage per vehicle was found to be 16.8 kg of Hythane<sup>®</sup>. Based on the fact that the vehicle switches to gasoline at 1 MPa, a usable quantity of Hythane<sup>®</sup> per vehicle was determined to be 16.2 kg. This was converted to an energy equivalent of 651.4 MJ which is 125% of the assumed daily requirement. For the purpose of conservative measurement, a design capable of providing 16.8 kg of Hythane<sup>®</sup> per day was made.

## 2.4.2 Proton Exchange Membrane Fuel Cell Sub-System

A fuel cell is a device that converts chemical energy into electrical energy. These devices are very efficient and have a very low environmental impact since their only emission is water. A proton exchange membrane fuel cell was chosen because of its high efficiency, high power density and its ability to start quickly<sup>(1)</sup>. Proton exchange membrane fuel cell is the most simple and economical fuel cell design also. It consists of two electrodes (anode and cathode) around an electrolyte membrane. Hydrogen is provided to the anode side where it is catalytically split into protons and electrons. The protons pass through the electrolyte to the cathode side. The electrons pass through an external circuit to the cathode, generating the current output of the fuel cell.

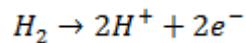

At the cathode, oxygen reacts with electrons taken from the electrode, and  $H^+$  ions from the electrolyte to form water.

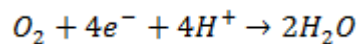

The PEMFC selected for the design is the *NedStack PS50* whose cost per kW is approximately \$1,419.8<sup>(2)</sup>. The PEMFC has a power density of 74.4 kW/m<sup>3</sup> and a specific power of 83.33 W/kg. The hydrogen flow rate required to provide 50 kW of power is 11 slpm/kW<sup>(3)</sup> or 2.9 kg H<sub>2</sub>/hr. Assuming constant production, the system will consume a total of 69.6 kg H<sub>2</sub>/day.

## 2.5 Major System Components

### 2.5.1 Auto Thermal Reformer

Auto thermal reforming (ATR) was chosen as the hydrogen production method for this design. This is a combination of two processes; catalytic partial oxidation and steam methane reforming. The chemical reaction can be shown as

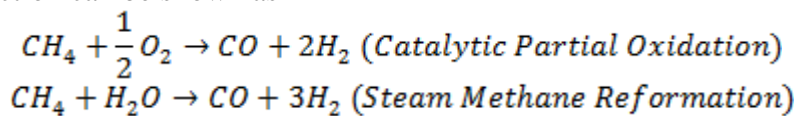

These reactions are followed by a water-gas shift reaction to use CO to produce more hydrogen.

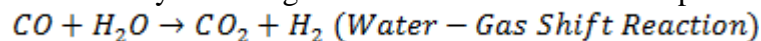

Using ATR, the heat generated in the exothermic, catalytic partial oxidation is used for the endothermic, steam methane reformation reaction. This increases the efficiency of the system.

The module selected for the design is the *HyRadix Adeo-100<sup>TM</sup>*. The system contains the capability of removing sulfur from incoming natural gas, producing hydrogen synthesis gas, and purifying the outgoing hydrogen with pressure swing adsorption technology. This system is capable of producing 216 kg/day. Initially, 24 hour maximum production will be used though the system is capable of operating at 25% of its rated capacity. Table 3 shows the specifications for the product.

Natural Gas	34.4 kg/h
De-Ionized Water	0.13 gal/min
Cooling Water	110-145 gal/min
Electric Power	30 kW

**Table 3: General Adeo Specifications**

Working with the above specifications provided by HyRadix, an overall energy balance was performed based on the mass flow into and out of the system. Also, the total heat required was found based on the chemical reactions shown above. The total energy efficiency was calculated to be 80% and the theoretical energy required per kilomole of fuel is 129.3kJ.

### 2.5.2 Hythane<sup>®</sup> Blender

The Hythane<sup>®</sup> Blender is a patented by Hythane Corporation. This device mixes natural gas and hydrogen at an 80/20 ratio by volume, respectively. As stated in patent US2006/0263283 A1, “the reliable operation of a gas blending and compression system depends upon striking a balance between blender production and compressor consumption.” An essential part of this system includes the controls where sensors are used to monitor the flow. For the purposes of the system at CAE, it is assumed that one vehicle will be filled every hour, which correlates to 16.8 kg/hr. The Hythane<sup>®</sup> Blender has a minimum volumetric flow rate of 87 Nm<sup>3</sup>/h (52.3 kg/h) which correlates to a mass ratio of natural gas and hydrogen of 97/3, respectively or required mass flow rates of 50 kg/h for natural gas and 1.57 kg/h for hydrogen. Since the reformer has an output rate of 9 kg H<sub>2</sub>/h and the fuel cells require a cumulative flow rate of 8.7 kg H<sub>2</sub>/h, the available flow rate to blend Hythane is 3 kg H<sub>2</sub>/h. Knowing this and that the available flow rate will only be needed periodically, a buffer system will be used to store a portion of the hydrogen output from the reformer. With this feeding the blender, it will only be required to run for approximately .3 hours or 18 minutes, daily.

### 2.5.3 Water De-Ionizer

De-ionized water is required for both the fuel cells and the reformer. Each fuel cell requires 120 slpm as a cooling medium while the reformer only requires .5 standard liters per minute (slpm). To meet these needs, the Marlo Incorporated *MSB-4284 680 KGR water de-ionizer* will be used.

### 2.5.4 Water Cooling Tower

The auto-thermal reformer requires the circulation of water at the rate of 110-145 gpm. The ArtiChill *ACT-60* will be used for this application.

### 2.5.5 Compressors

To understand the power that is required for the various compressors, the following analysis was done. The isentropic overall efficiency of the compressors was determined from the following equation<sup>(26)</sup>.

$$\eta_{isentropic} = \frac{\text{Isentropic Compressor Power}}{\text{Actual Compressor Power}} = \frac{\dot{m}c_p T_1 \left[ \left( \frac{P_2}{P_1} \right)^{\frac{k-1}{k}} - 1 \right]}{\dot{W}_{shaft}}$$

where  $\dot{m}$  is the mass flow rate through the compressor,  $c_p$  is the specific heat at constant pressure and  $k$  is the specific heat ratio.  $T_1$  was assumed to be 300 K and the pressures were found according to system requirements. According to “Thermodynamics – An Engineering Approach”, well-designed compressors have isentropic efficiencies between 80 and 90 percent. Assuming an efficiency of 80%, the shaft power was calculated. Next, the power required for the electric motor was determined by assuming 80% electric motor efficiency and using the following equation

$$\eta_{electric\ motor} = \frac{\text{Mechanical Power Out}}{\text{Electrical Power In}} = \frac{\dot{W}_{shaft}}{\text{Electric Power (kW)}}$$

### 2.5.5.1 Compressor One – Natural Gas

The natural gas used in the reformer must be compressed because according to South Carolina Gas and Electric, the utility line can be supplied at 172 kPa (25 psig) while the reformer requires 1000 kPa (145 psig). Because compressed natural gas is required for both the compressor and the reformer, the sum of the maximum flow rates for both applications was used to ensure that the compressor could handle the maximum load. Table 4 shows a summary of the calculation.

$\Delta P$	120 psig = 827.37 kPa
Mass flow rate	92 kg/h
<b><i>Electrical Power Required</i></b>	<b><i>10.2 kW</i></b>

**Table 4: Natural Gas Compressor Requirements**

### 2.5.5.2 Compressor Two – Hydrogen

Because the blender requires a flow rate higher than what the reformer can produce, a buffer system will be required to accumulate the necessary amount of hydrogen. Since the output pressure from the reformer is 689 kPa (100 psig), a compressor capable of compressing up to 6500 kPa (950 psig) will be used to reduce gas storage volume with a maximum flow rate of .3 kg/h (2 scfm). At this pressure, hydrogen is not considered to be an ideal gas. To estimate compressor requirements, an *A1 Series* compressor from *Fluitron* was used as a reference which has a maximum discharge pressure and flow of 3450 kPa (500 psig) and 1.2 scfm respectively, and draws 3 hp (2.24 kW) <sup>(20)</sup>. Based on this, the actual power required for this system's application is estimated to be 5 kW.

### 2.5.5.3 Compressor Three – Hythane<sup>®</sup>

To increase the efficiency of the dispensing system, a three staged compressor was selected. As discussed in section 2.3.2, the flow through the dispensing system is dictated by the minimum flow allowed through the Hythane<sup>®</sup> blender. The system will be set such that the compressors for the cascade tanks will only run when the blender begins to run. The blender run time is dictated by a pressure drop in the tanks. Again, the assumption is that one car will be refueled every hour for six hours.

To ensure that the Hythane<sup>®</sup> can be considered as an ideal gas and thus the previous equations applied, the following ratio was calculated:

$$Z = \frac{v_{actual}}{v_{ideal}}$$

where  $Z = 1$  indicates ideal gas. At 25 MPa (3600 psi)  $v_{actual}$  is .00654 m<sup>3</sup>/kg and  $v_{ideal}$  is equal to  $RT/P$  which is equal to .00624. The ratio is equal to 1.05 which is sufficient to allow for the ideal gas assumption. In the following table, the stage requirements are listed based on the thermodynamic analysis in section 2.5.5.

<b>Compressor 1 (Low Pressure)</b>	
$\Delta P$	$P_{in}=100\text{kPa}$ , $P_{out}=10000\text{kPa}$ , $\Delta P = 9900\text{kPa}$
Mass flow rate	58.8 kg/h
<b>Electrical Power Required</b>	<b>32.5 kW</b>
<b>Compressor 2 (Middle Pressure)</b>	
$\Delta P$	$P_{in}=10000\text{kPa}$ , $P_{out}=20000\text{kPa}$ , $\Delta P = 10000\text{kPa}$
Mass flow rate	53.174 kg/h
<b>Electrical Power Required</b>	<b>2.7 kW</b>
<b>Compressor 3 (High Pressure)</b>	
$\Delta P$	$P_{in}=20000\text{kPa}$ , $P_{out}=34000\text{kPa}$ , $\Delta P = 14000\text{kPa}$
Mass flow rate	40.7 kg/h
<b>Electrical Power Required</b>	<b>1.5 kW</b>

**Table 5: Hythane Compressor Requirement**

A compressor, model number 05H25NGDX, manufactured by P.C. McKenzie Company was found to satisfy the requirements for the dispensing system. Table 6 below lists the specifications for the compressor<sup>(23)</sup>.

	Compressor Specifications	System Requirements
Minimum Inlet Pressure	5 psig (35 kPa)	100 kPa
Maximum Discharge Pressure	5000 psig (34473 kPa)	34000 kPa
Flow Capacity	56 scfm	51.185 scfm
Electrical Power Requirements	50 hp (37.2 kW)	

**Table 6: Compressor Specifications**

To determine the equilibrium pressure in each tank during the dispensing process, the following equation was used, assuming isothermal conditions:

$$\frac{P_{vehicle}V_{vehicle}}{RT} + \frac{P_{storage}V_{storage}}{RT} = \frac{P_{equilibrium}(V_{storage} + V_{vehicle})}{RT}$$

	<b>Maximum Tank Pressure</b>	<b>Equilibrium Pressure</b>
<b>Low Pressure Tank</b>	10 MPa	7.231 MPa
<b>Medium Pressure Tank</b>	20 MPa	16.464 MPa
<b>High Pressure Tank</b>	34 MPa	29.144 MPa

**Table 7: Equilibrium Tank Pressures**

The starting vehicle tank pressure at each fill is assumed to be 150 psi (1.034 MPa). This is the minimal allowable pressure for the vehicles before the fueling automatically switches to gasoline. Also, the maximum fill pressure for each vehicle is 3600 psi (24.82 MPa). It can be seen that the fill will be finished before the last tank reaches equilibrium.

### 2.5.6 Hydrogen Storage Buffer

The mass of hydrogen to be stored for this design will be 3 kg. This is the amount needed to produce enough Hythane<sup>®</sup> for six vehicles for one day. Because hydrogen will not be dispensed at the current time, storage can occur at lower pressures. 6500 kPa (950 psi) was selected as the storage pressure. Because this is less than 28 MPa (4000 psi), the ideal gas law can be used. The specific volume was determined to be .57 m<sup>3</sup>. Knowing this, three storage tanks with .19 m<sup>3</sup>

volume will be used. Lincoln Composites Tuffshell<sup>®</sup> fuel tanks will be used <sup>(21)</sup>. Because the pricing was not available, estimates were used.

## 2.6 Dispensing System

### 2.6.1 Dispensing unit

A dispenser produced by FTI International will be used. This dual hose dispenser is capable of dispensing hydrogen at 5000 psi and a compressed natural gas blend with hydrogen at 3600 psi. Because this unit is capable of dispensing both fuels, the transition cost into the pure hydrogen infrastructure will be minimized.

### 2.6.2 Cascade storage tanks

Various storage and dispensing mechanisms were considered for the purpose of this project. A booster compression system, consisting of a low pressure storage vessel and a compressor capable of compressing up to the required vehicle storage pressure, was considered. This option was rejected because if the fleet of vehicles serviced by the station expands, this system would be slow, requiring extensive time for recharging the storage tank. To allow for growth, a cascade storage system was selected that employs three tanks, operated in serial fashion.

To determine the pressures required for the tank system, the theory of compressible flow was applied. Using the properties of methane to simplify the calculations, the speed of sound was determined to be approximately 450 m/s at 300 K. When the discharge fluid velocity reaches the speed of sound, the Mach number, which is defined as the ratio velocity to the speed of sound in the same fluid, equals one <sup>(6)</sup>. An isentropic state was also assumed because of its recognized validity for most nozzle, diffuser, and turbine systems <sup>(6)</sup>. In addition, the gas was considered ideal to simplify the problem. Fluid mass flow changes with variation in the Mach number. Maximum mass flow occurs at sonic conditions and it decreases as both subsonic and sonic conditions are approached. “Thermodynamics – an Engineering Approach” notes that the maximum velocity that can be achieved in a converging nozzle is sonic velocity. Critical properties are defined as properties in which the Mach number is 1. The critical pressure ratio is

$$\frac{P_{nozzle}}{P_{tank}} = \left(\frac{k+1}{2}\right)^{\frac{k}{k-1}}$$

where  $k$  is the specific heat ratio,  $\frac{c_p}{c_v}$  for the gas. Though sonic flow only occurs at the throat of the nozzle, the goal of the design was to size the tanks such that the pressures allow for operation at near sonic levels. Mass flow rate is dependent on both the tank pressure and the Mach number.

$$\dot{m} = \frac{\sqrt{k/(RT_o)AMaP_o}}{[1 + (k-1)Ma^2/2]^{(k+1)/[2(k-1)']}}$$

Though mass flow does increase with increasing reservoir pressure, if the first tank in the cascade is compressed to high pressures, a supersonic condition would occur. Because of the small size of the vehicle tanks, the fill time is quite short (see the appendix for a pressurization curve) and using lower pressures will allow for higher overall system efficiency because less energy will be required for compression given a fixed mass flow rate out of the system per day. The critical pressure ratio for this design was determined to be 0.5, assuming a  $k$  value of 1.3.

The pressure ratio at the beginning of each stage was determined and compared to the critical pressure ratio. The system is designed such that the first two tanks end their fills just as the flow becomes sub-sonic. The highest pressure tank will then finish the fill. The starting and ending pressure ratios are shown in the table below.

	<i>Maximum Tank Pressure</i>	<i>Vehicle Tank Pressure at Start of Fill</i>	<i>Pressure Ratio at the Start of Fill</i>	<i>Pressure Ratio at the End of Fill</i>
<i>Low Pressure Tank</i>	10 MPa	1.034 MPa	.10	.53
<i>Medium Pressure Tank</i>	20 MPa	4.013 MPa	.20	.52
<i>High Pressure Tank</i>	34 MPa	8.648 MPa	.25	.89

**Table 8: Pressure Ratio for Each Tank**

Piston style compressors are like engines. The pistons use rings to seal the compression chambers and these seals are not perfect. In fact, they leak and their leakage is generally directly proportional to the pressure drop across them; therefore, increasing the chamber pressure increases the leakage. The delivery volume of the compressor is the theoretical flow (displacement x rpm) - leakage. The leakage flow term (volumetric flow rate) can be described by using the equation for steady, laminar, axial flow through an annulus<sup>(28)</sup>

$$Q_L = \frac{\pi \Delta P}{8 \times \mu \times L} \left[ r_o^4 - r_i^4 - \frac{(r_o^2 - r_i^2)^2}{\ln(r_o/r_i)} \right]$$

where  $r_o$  is the radius of the bore plus the clearance distance between the bore and the cylinder,  $r_i$  is the radius of the bore,  $\mu$  is the fluid viscosity, and  $L$  is the axial sealing land length.

This shows that the leakage flow is directly proportional to the pressure drop. It is conceivable, especially with a worn compressor, that leakage flow will approach the theoretical flow. At this point, the compressor will not achieve the shutoff pressure and run for extended periods of time where they can overheat and the motor shuts down due to excessive electrical current draw. A conclusion can be made that this system, which charges the tanks at serial pressures, will require the compressor to run for less time because a smaller amount of leakage can be expected and thus the charge will be more volumetrically efficient.

To design and analyze cascade storage systems, CASCADE<sup>TM</sup> software can be used. Though it was not available for the use in this design, the reaffirmed the design idea by stating, "Cascade storage works on the principle that banks of vessels at different pressures can more efficiently fill a vehicle than bulk storage, or operation of the total storage capacity as a unit at a common pressure<sup>(29)</sup>."

To determine the tank volume and pressure, the following assumptions were made.

1. Hythane<sup>®</sup> is an ideal gas
2. One day's worth of buffer will be held in each tank to prevent a shortage if the hydrogen production not operational
3. Dispensing is an isothermal process,  $T = 300\text{K}$
4. The tanks will refill after one vehicle filling
5. Each tank will have the same volume

Using the Law of Conservation of Mass following formula was used to determine the tank volume

$$\sum_{i=1}^m \frac{P_i V_{\text{tank}}}{RT} = n \times V_{\text{vehicle}} \times \rho_{\text{Hythane}}$$

where  $n$  is the number of vehicles to be filled and  $m$  is the number of tanks in the cascade system. Because the system is currently being designed for six vehicles, the system can be expanded as more vehicles require fueling by adding three tanks in parallel to the existing tanks. The volume of each tank was determined to be 290 L. This volume will store seven vehicles worth of Hythane<sup>®</sup> with one vehicle worth being a transient volume and six vehicles worth being a static buffer.

## 2.7 Electrical Requirements

The electrical output power of a fuel cell is in DC voltage which is not typically compatible with most electrical installations. Therefore, this voltage has to be regulated and converted into a usable AC voltage. A number of technologies are available for power conversion systems (PCS).

SatCon Power Converter System (PCS) uses a proprietary technology capable of controlling the power coming from the fuel cell and incorporates a high efficiency transformer. SatCon technology can operate in both grid-connected and grid-independent configurations. If necessary, it can be easily switched between the two configurations<sup>(14)</sup>.

The DC to AC conversion is performed by three SatCon Power Gate AE-FC series. The output voltage for each fuel cell is 600 VDC. This voltage is converted into 480 VAC, 3 Phase, 60 Hz and then introduced to the utility grid. The configuration of the system is set up so that each set of fuel cell and Power Converter System is independent of other sets. In the event that one of the fuel cells fails or needs to be stopped for any reason, the configuration permits the others to continue delivering power into the utility grid.

SatCon technologies reserves the right to withhold a budget price from non commercial parties. Therefore, the estimated cost for SatCon Power Gate AE-FC is not available. For the purpose of this design, the system cost was estimated by comparing SatCon Power Gate AE-Fuel Cell technology with Power Gate AE-Photo voltaic technology. Both Power Conditioning Systems used the same basic converting principle.

### 2.7.1 Selection of Transformers

Article 501 of the National Electrical Code establishes the utilization of dry type transformers for locations where the atmosphere may contain hazardous vapors, including natural gas or methane.<sup>(16)</sup> Also, it can be found that two transformers are needed to supply the required voltages. The characteristics for each transformer are listed below:

	Phases	Volts Primary	Volts Secondary	Frequency (Hz)	kVA
Transformer 1 <sup>(17)</sup>	3	480V-Delta	208V-Y/120	60	30
Transformer 2 <sup>(18)</sup>	3	480V-Delta	480V-Y/277	60	112.5

**Table 9: Transformer characteristics**

Table 10 gives a tabulation of the distribution of the loads according to the type of transformer and voltage that is required for each component. The kVA of the transformer should be equal to or greater than the kVA of the load to handle present requirements and to account for future expansion.

For transformer 1 with a kVA of 25.529 kVA, the closest commercial value is 30 kVA. For transformer 2 the closest commercial value is 112.5 kVA, giving both transformers the ability to handle future expansions<sup>(19)</sup>. See the appendix for details

	Component	Voltage (V <sub>ac</sub> )	Amp (I)	Phase	Power (kW)	KVA
<b>Transformer 1</b>	Hythane Blender HX500	120	1.961	1	0.17	0.2
	Deionizer	120	1.765	1	0.18	0.21
	Hydrogen generator Adéo-100 TM – Aux	120	0.686	1	0.07	0.082
	Cooling Tower ACT 100	208	7.184	3	2.2	2.588
	Compressor 1 – NG	208	18.157	3	5.56	6.541
	Compressor 2 – H <sub>2</sub>	208	44.151	3	13.52	15.906
<b>Transformer 2</b>	Adéo-100 TM – Main Power	480	42.453	3	30	35.294
	Compressor 3 – NG	480	52.642	3	37.2	43.764
	Super Charge TM GSE-200DP	480	21.226	3	15	17.647

**Table 10: Distribution of load**

## 2.8 System Daily Use

As previously described, three compressors will be required for the function of the system. The natural gas compressor coupled to the reformer will run continuously with reformer. The hydrogen compressor will be required to run for 10 hours per day at a rate of .3 kg/h to generate the 3 kg currently needed for the Hythane<sup>®</sup> blending. Finally, the Hythane<sup>®</sup> dispensing compressor will operate for 18 minutes after each vehicle fills. Below as a graph which details the daily power consumption by the system. After the hydrogen tanks are filled, the reformer will be turned down to only produce the amount of hydrogen required for the fuel cells.

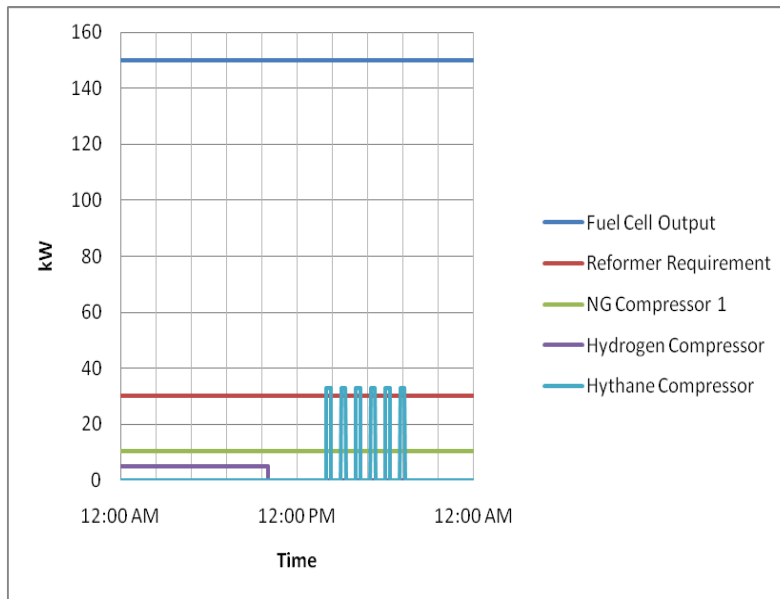

**Figure 4: Daily Power Production and Consumption**

## **3.0 Safety Analysis**

### **3.1 Introduction**

A thorough safety protocol is a very important component of a design or a process, especially when flammable gases or liquids are involved. Airports have been the leaders in safety and the only industry achieving six sigma goals in terms of safety. Prevention of accidents in the process of generating and using hydrogen will promote the public acceptance of hydrogen use.

Hydrogen and Hythane<sup>®</sup> storage containers, safety relief devices, piping, tubing, fittings, equipment assembly, location and capacity are all designed and installed in accordance with U.S. Department of Labor Occupational Safety & Health Administration (OSHA) - Regulations (Standards - 29 CFR), Hydrogen 1910.103. The design is in accordance with ASME Boiler and Pressure Vessel Code, U.S. Department of Transportation Specifications and Regulations, and Industrial Gas and Air Piping (ANSI).

### **3.2 Design Safety**

#### **3.2.1 Storage Tanks**

Storage tanks are provided with noncombustible supports on firm noncombustible foundations. Each storage tank will be marked clearly with the type of gas which is being stored. Storage tanks will be equipped with safety relief devices.

#### **3.2.2 Piping, Tubing, and Fittings**

Piping, tubing, and fittings must be suitable for hydrogen service and for the pressures and temperatures involved. According to ANSI/ASME B31.3 stainless steel 303, 304, or 316 is preferred for hydrogen tubing, piping, and fitting. Further, the maximum hardness is specified as 80 Rb. Joints in piping and tubing will be made by welding, brazing or by use of flanged, threaded, socket, or compression fittings.

#### **3.2.3 Location and Construction**

The design will be open to the environment and surrounded by a protective ten foot fence. This will ensure that only authorized personnel enters the facility. During the construction of the hydrogen park, the FAA code AC 150/5370-2 which describes the regulations for construction on airport grounds, will be followed.

### **3.3 Process Safety**

#### **3.3.1 Manual Emergency Shut-Down**

Manual emergency shut-down “E-stop” push buttons are strategically placed in the facility to initiate immediate shut-down of all processes, close the shut-off blocking valve, and open relief valves throughout the system.

#### **3.3.2 Valves**

Hand valves are placed on piping before and after every unit operation to isolate certain systems in case of automated control failure and will allow for preventative maintenance inspection on all

components to check for leakage and verify that components are operating within design limits. Maxon double blocking valves are installed on the natural gas utility gas train to shut off supply in case of emergency. Finally, relief valves are placed on piping located near the compressors.

### 3.3.3 Gas Detection and Fire Suppression

Hydrogen gas, natural gas and smoke detectors are strategically located throughout the facility. A fire suppression system will cover the entire facility and activate in the case fire emergency.

### 3.3.4 Programmable Logic Control (PLC)

Various sensors will be used to detect hazardous conditions. These sensors will detect hydrogen, natural gas, hydrogen flame, and smoke. Measuring devices, including thermocouples, pressure gauges, and flow meters, will be used to monitor system performance. All sensors and measuring devices are connected to the PLC and will continuously provide system data. The PLC signals solenoid valves to actuate close or open to divert flow, shut down certain processing units, open relief (vent) valves, and release extinguishing agents in case of hazard. The PLC is connected to a human machine interface (HMI) that displays to the operator the real-time status of the entire operation and lists warnings & alarms of out of specification limit measurements.

## 3.4 Major Failure Modes

Although the design follows the safety codes and regulations in the construction and operation of the facility, some hazards may still appear. A Failure Mode and Effects Analysis (FMEA) was used to ensure that all major sub-system failure modes were considered. Details are included in the appendix. The table below highlights the major sub-system failure modes.

Item	Potential Cause of Failure	Current Design Controls
Reformer	Damage to the reformer vessel or possible fuel leakage	Install pressure sensors to monitor outlet and vessel pressures. PLC will shut off reformer, feed NG, and DI water into reformer. Warning will be sent to the Human-machine interface (HMI). Install LEL detectors to monitor for the presence of H <sub>2</sub> .
Hythane <sup>®</sup> Dispenser	Dispenser filling hose leak	Install pressure gauges with warning system that shuts down system in an under-pressurized condition
Cooling Tower	Leakage within the cooling tower water supply piping and/or pump leak	Pressure gauges and flow meters installed in water supply and return piping. PLC to warn HMI if flow rate or pressure drop to over 90% of set points. PLC to shut off reformer and NG gas feed into reformer.
	UV light failure (leading to high bacteria count)	Periodic manual inspection of UV light bulb. PLC to monitor number of hours the bulb has been on for. PLC to warn HMI if bulb life as surpassed 110% of bulb life rating.
Hythane <sup>®</sup> Blender	H <sub>2</sub> and/or CH <sub>4</sub> leakage within feed piping or interface	Install modulating valves interfaced to the PLC to monitor and adjust incoming gas pressures.

**Table 9: Major Sub-System Failure Modes**

Aside from sub-system failures, two major failures due to improper operation were considered.

### 3.4.1 Vehicle Crashing into the Hydrogen-Hythane<sup>®</sup> Dispenser

To prevent hazards such as a fire or explosion as a result of a vehicle crashing into the dispenser, steel reinforced concrete beams will surround the dispenser. In the case of hydrogen or Hythane<sup>®</sup> line rupture at the dispenser, the programmable logic control (PLC) will terminate the fuel flow to the dispenser by shutting off the control valve, as a result of the loss of the pressure.

### 3.4.2 Vehicle drives away with refueling hose attached

To avoid the hazard of driving away while fuel dispensing is in progress, a palm button will be installed and linked to the PLC. The PLC will not permit fueling unless the driver's hand is placed on the palm button. Once the driver removes his or her hand the fueling stops. The hose will also include a breakaway nozzle, such that the nozzle will stay attached to the vehicle yet will disconnect from the hose.

## 3.5 System Analysis Simulation

To validate the operation and safety of the design, a simulation of the power station was created. A program was written that simulates normal and critical operation of all major components. The program also simulates all failure modes, which affect the safety and the sensors that detect failure the modes. The program was written using Labview 8.5 software which is widely used in engineering applications. The simulation program allows for testing the design in as close to real life condition as possible. Using the simulation the design was optimized and improvements in the safety were made. To the right is a view of how the simulation appears to the user.

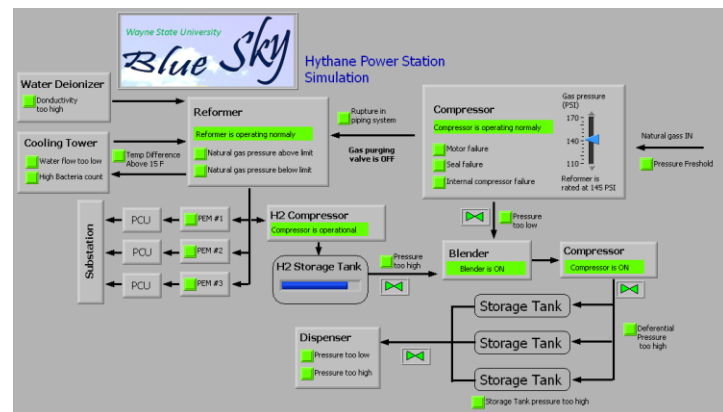

Figure 5: User Interface for System

As an example, Figure 6 demonstrates one of the failure modes. Because the reformer requires that compressed natural gas at a specific pressure of 145 psi +/- 10 psi, pressure outside of the range is a failure mode. If the pressure exceeds the upper limit or falls below lower limit, the system will lose function and cause a possible safety concern. A virtual pressure sensor was placed between natural gas compressor and the reformer. The pressure sensor continuously monitors the pressure generated by natural gas compressor and in the event of failure mode, the reformer is shut down and a valve between the compressor and reformer is turned off.

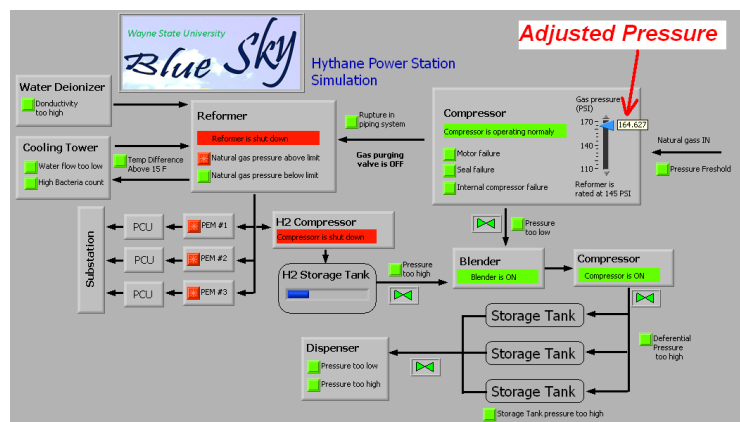

Figure 6: Example Simulation of a Failure Mode

## 4.0 Economic Analysis

### 4.1 Capital Costs

The project budget is \$3 million for capital, installation, transitional, and marketing costs. Blue Sky Energy Solutions created a system that provides both economic and environmental benefits. Below is a table of capital costs.

<b>Basic Hythane Fueling System*</b>	<b>Auto-Thermal Reformer*</b>
Hythane Compressor	HyRadix Adeo 100
Hythane Blender	De-ionizer
Hythane Dispenser	Cooling Tower
Master Control w/ Card Reader Access	<b>SUB-TOTAL</b> <b>\$700,000</b>
Sequence & Priority Controls	<b>Pure Hydrogen Equipment*</b>
Hythane 5000 psi Storage Tanks	Hydrogen Compressor
Piping, Valves & Regulators	Hydrogen Buffer Tank
<b>SUB-TOTAL</b> <b>\$537,870</b>	<b>SUB-TOTAL</b> <b>\$60,000</b>
<b>Calibration*</b>	<b>Miscellaneous</b>
Airport vehicle engine calibration	The Conservation Fund - Go Zero Donation \$100,000
Engine Conversion Kits for 6 vehicles	<i>eTec SuperCharge</i> <sup>TM</sup> GSE-200DP \$26,000
<b>SUB-TOTAL</b> <b>\$250,000</b>	Marketing \$50,000
<b>Vehicle Hardware Conversion</b>	<b>SUB-TOTAL</b> <b>\$150,000</b>
Basic Hardware Conversion cost from ATW Automotive (6) \$31,200	<b>Design, Engineering and Labor</b>
Additional cost for 3600 psi tanks (6) \$2500	System Installation & Start up & Commission \$100,000
<b>SUB-TOTAL</b> <b>\$33,700</b>	Complete system design \$100,000
<b>Fuel Cell*</b>	Civil engineering- site preparation, FEMA, codes, training etc \$375,000
NedStack 50 kW PEM Fuel Cell (3)	<b>SUB-TOTAL</b> <b>\$575,000</b>
AC/DC Converter-electrical equipment	
<b>SUB-TOTAL</b> <b>\$458,633</b>	
<b>Total</b>	<b>\$2,766,203</b>

**Table 10: System Capital Costs**

\* Itemized costs were not available for many components due to the desire of the company's to keep information proprietary.

An important consideration for the design is its actual operational costs including equipment and personnel. Table 11 shows the estimated cost for personnel to operate and maintain the system on a daily basis.

<b>Personnel Cost</b>			
<b>Personnel</b>	<b>Quantity</b>	<b>Yearly Cost</b>	<b>Subtotal</b>
<b>Staffing</b>			
-Operator/Technician 2hrs/day @ \$20/hr	1	\$10,000	\$10,000
<b>Engineering Support</b>			
-Technical Analyst	As Needed	\$20,000	\$20,000
<b>TOTAL PERSONNEL COST</b>			<b>\$30,000</b>

**Table 11: Personnel Rates**

To determine the running cost of the system an analysis was done using South Carolina Electric and Gas rates. See Table 12 for a summary of utility operational costs.

<b>Natural Gas Rates</b>	
Excess over 50 dekatherms	\$6.79/dekatherm
Commodity Charge	\$1.39/dekatherm
<b>TOTAL</b>	<b>\$8.18/dekatherm</b>
<b>Electricity Rates</b>	
Rate at Peak Hours (summer-rate)	\$.05365/kWh
Rate at Non-Peak Hours	\$.03168/kWh
<b>Water Rates</b>	
Unit Cost	\$.0252/ft <sup>3</sup>

**Table 12: Utility Rates**

Using these rates, the running cost of the reformer was determined.

	<b>Required Rate</b>	<b>Cost</b>
<b>Natural Gas</b>	1873 scfh = 1.873 dekatherm/h	\$15.32/h
		\$367.71/day
<b>Electricity</b>	Power = 30 kW	\$1.6095/h (peak)
		\$.9504/h (non-peak)
	Energy = 240 kWh (peak), 480 kWh (non-peak)	\$12.876/day (peak)
		\$15.2064/day (non-peak)
<b>Water</b>	.02952 m <sup>3</sup> /h	\$0.026271/h
		\$.6305/day
<b>TOTAL</b>		<b>\$396.42/day</b>

**Table 13: Operating Costs**

The cost of the Hythane<sup>®</sup> required per vehicle per day was also determined. The amount of fuel required is based on the analysis previously described in section 2.4. This was compared to the cost of gasoline. See the table below.

	<i>Amount Required</i>	<i>Cost per Unit</i>	<i>Total Cost</i>
<i>Natural Gas</i>	16.3 kg/day	\$.45/kg	\$7.27/day
<i>Hydrogen</i>	.5 kg/day	\$1.84/kg	\$.92/day
<b>TOTAL</b>			<b>\$8.19/day</b>
<i>Gasoline</i>	4.4 gal/day	\$3/gal	\$13.2/day
<b>Total Savings per Day per Vehicle</b>			<b>\$5.01</b>

**Table 14: Total Savings per Day per Vehicle Using Hythane**

To determine how the cost of Hythane<sup>®</sup> is influenced by the cost of natural gas, a plot was made. To do this, the electrical cost was assumed to remain at its current level. The amount of Hythane<sup>®</sup> and gasoline required per day, listed in Table 14, was used. The plot shows that natural gas will have to be \$0.70, \$0.85, and \$1.00 to be more expensive than gasoline when priced to \$3.00/gal, \$3.50/gal, and \$4.00/gal, respectively.

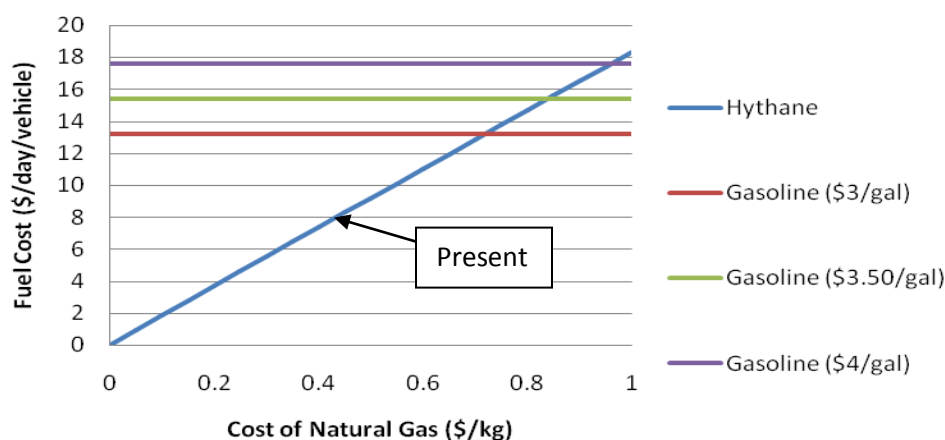

**Figure 7: Cost of Hythane with Varying Natural Gas Prices Compared to Gasoline Cost**

### 4.3 Voluntary Airport Low Emissions Program

Though the system is expensive, benefits will be obtained from the conversion of ground vehicles to an alternative fuel. The Federal Aviation Administration (FAA) created the Voluntary Airport Low Emissions Program (VALE). The FAA notes that “The goal of the VALE program is to help airports to improve air quality in conjunction with regional efforts to meet health-based national ambient air quality standards.” This program offers financial incentives to increase the investment in alternative fuels. Though the grants that could be incurred from this program could not be included in the analysis, it should be recognized that they exist. The FAA recognizes that it is not possible for the airport to control the emissions of the airplanes, but through this program they hope to encourage airports to reduce emissions from what is in their control – ground vehicles<sup>(25)</sup>.

## 4.4 Maintenance Cost

The following maintenance cost and schedule is based on manufacturer's recommendations and assumptions based on similar equipment. These prices reflect the cost for a trained technician to perform all the required maintenance and supply the consumable parts. Additional costs may be incurred for unexpected repairs that do not fall under the manufacturer's warranty.

<i>Component</i>	<i>Expected Life</i>	<i>Time Until Maintenance</i>	<i>Maintenance Cost/year</i>
Reformer/Cooling Tower/Deionizer	15 years	15 years	\$10,000
Compressor (3)	5 years	1 year	\$9,000
Fuel Cells (3)	2 years (about 20000 hours)	2000 hours	\$50,000
Blender	6 years	2 years	\$1,000
Dispenser	6 years	2 years	\$1,000
Total Yearly Maintenance Cost			\$71,000

**Table 15: Expected Maintenance**

## 4.5 System Outlook

Blue Sky Energy Solutions plans to convert 20 of CAE's vehicles to Hythane<sup>®</sup> after two years. Below is a table that details the cost savings. The savings per vehicle was assumed to increase due to an increase in gas price and a conversion of vehicles that use more fuel per day. Also airline owned vehicles will be eligible for Hythane fueling at market rates. If sold at \$4.5 per kilogram, the airport can expect to experience a 6% rate of return. A detailed table can be found in the appendix. Because more hydrogen will be needed for the vehicles, less electrical power will be able to be produced. Below is a table summarizing the net income and savings for the first four years.

Year	1	2	3	4
Net Income/Savings	\$-158,680	\$-158,680	\$425,613	\$625,613

**Table 16: Net Income/Savings**

## 4.6 Hydrogen Production Site Overall and Future Value Added

<b>Course of Action</b>	<b>Description</b>
Fuel Cell Awareness Course	Staff taught classes at market rate
Hydrogen Technology Awareness Course	Staff taught classes at market rate
Business Alliance/Sponsorship	Vehicle donation to allow company promotion
Hythane <sup>®</sup> Sold to Airlines/Shuttles	Airline bought Hythane <sup>®</sup> at market rate
Local University Tours	Raise awareness to academic fields
High School Scholarship Competition	Raise awareness to academic fields
Voluntary Airport Low Emissions Program	Clean air grants/alternative technology grants

**Table 17: Values Added From Design**

## 5.0 Environmental Analysis

### 5.1 Air Quality

#### 5.1.1 CO<sub>2</sub> Analysis

A major issue experienced by airports nationwide is emissions. An obvious source of emissions is the airplanes and ground vehicles on site. In addition to this, airports are open 365 days/year for 24 hours, requiring a large amount of electrical energy. This electricity is provided by a grid, which though it does not add to the local emissions of the site, is a large contributor to the emissions of the state and should be considered. First a breakdown of the electrical grid sources was defined.

Coal	39.90%
Petroleum	0.50%
Natural Gas	1.80%
Nuclear	53.80%
Hydroelectric	3.90%
Other Renewable Sources	1.40%

**Table 18: Breakdown of South Carolina Electrical Power Grid Sources<sup>(11)</sup>**

Next, the emissions from each source were found.

Coal	0.986	kg/kwh
Petroleum	0.935	kg/kwh
Natural Gas	0.45	kg/kwh
Nuclear	0.0305	kg/kwh
Hydroelectric	0.025	kg/kwh
Other Renewable Sources	0.435	kg/kwh

**Table 19: CO<sub>2</sub> Emissions for Each Source<sup>(10)</sup>**

Taking into account the amounts listed in Table 19 and the relative percentages, the amount of emissions was determined to be approximately .43 kg/kWh.

A second source of carbon dioxide is vehicles. The Energy Information Administration listed that gasoline vehicles release 7.9 mol CO<sub>2</sub>/vehicle mile traveled and compressed natural gas vehicles release 5.64 mol CO<sub>2</sub>/vehicle mile traveled. Hythane reduces the carbon dioxide emissions by an additional 7%. See the appendix for a case study of the effects of using a blended fuel.

To determine the net reduction in carbon dioxide emissions, the power produced, vehicles converted and carbon dioxide emitted from the system were considered. A net reduction of carbon dioxide emissions was determined to be 24%

<b><i>Carbon Dioxide Emission Reduction From Power Production</i></b>		
Maximum Power Production	150 kW	
Hours of Production	24 hours	
Total Energy	3600 kWh/day	
Carbon Dioxide Emission Reduction per day		1547 kg CO <sub>2</sub> /day
<b><i>Carbon Dioxide Emission Reduction From Vehicle Conversions</i></b>		
Assumed Distance Traveled per Day	40 miles	
Gasoline Emissions <sup>(12)</sup>	83.4 kg/day for 6 vehicles	
Compressed Natural Gas Emissions <sup>(12)</sup>	59.57 kg/day for 6 vehicles	
Hythane ® Emissions	55.4 kg/day for 6 vehicles	
Emissions Reduction per Day for 6 Vehicles		28 kg CO <sub>2</sub> /day
<b><i>Carbon Dioxide Emissions From System</i></b>		
Emissions Produced from Reformer	786 kg/day	
Total System Energy Requirement	1077 kWh/day	
Emission Production from Electrical Requirement	462.7 kg/day	
Emissions Production per Day From the System		1248 kg CO <sub>2</sub> /day
<b>NET CARBON DIOXIDE REDUCTION</b>		<b>325 kg CO<sub>2</sub>/day</b>
		<b>&gt; 125 tons/year</b>

**Table 20: Net Reduction in Carbon Dioxide**

As more vehicles are converted to Hythane<sup>®</sup>, especially shuttles that run for many hours per day, the carbon dioxide emission reduction will increase. Further, as hydrogen fuel cell vehicles or internal combustion engines become more economically feasible, emissions will be reduced dramatically. This system will give the airport the ability to become comfortable with an alternative fuel and allow for compliance to strict emissions standards.

Because carbon dioxide sequestering is not currently feasible, natural means to reduce carbon dioxide have been considered. Any photosynthetic organism uses carbon dioxide for metabolic purposes. Technologies have been developed to incorporate algae, yet the planting of trees is often overlooked. Blue Sky Energy Solutions will donate \$100,000 to The Conservation Fund's Go Zero program. For \$5/tree, The Conservation Fund plants trees to address the issue of climate change <sup>(13)</sup>. Because their current efforts are in the southeast, including South Carolina, this investment was deemed appropriate. The table below details the net carbon dioxide that can be expected to be absorbed per year.

Investment Amount	\$100,000
Cost per Tree	\$5.00
Number of Trees Purchased	20,000
Carbon Dioxide Reduction per Tree	.0133 tons CO <sub>2</sub> /year
Total Amount of Carbon Dioxide Absorbed	266 tons CO <sub>2</sub> /year (241,311 kg CO <sub>2</sub> /year)

**Table 21: Go Zero Carbon Dioxide Sequestering Program Effects <sup>(13)</sup>**

### 5.1.2 NO<sub>x</sub> Analysis

Through the appropriate calibration offered by Hythane Corporation, the NO<sub>x</sub> emissions can be reduced by at least 50% from those experienced by compressed natural gas vehicles. The Energy

Information Administration noted that gasoline vehicles emit 26.5 mill-moles per vehicle mile traveled while compressed natural gas vehicles emit 24.2 mill-moles per vehicle mile traveled. Hythane<sup>®</sup> will be expected to reduce emissions to 12.1 mill-moles per vehicle mile traveled. This results in a net savings of approximately 26.5 g NO<sub>x</sub>/vehicle/day.

### 5.1.3 Hythane<sup>®</sup> Vehicle Case Study

Testing performed by the Arizona Public Service, in conjunction with the US Department of Energy, investigated the emissions from a Ford F-150 pickup truck modified to operate on a blend of 28 percent (by volume) Hydrogen with 72 percent compressed natural gas. The testing ran for almost one year, during which the truck logged over 16,000 miles. The figure to the right summarizes the data taken from the Arizona/Ford F-150 testing. See the table below for a tabulation of the results.

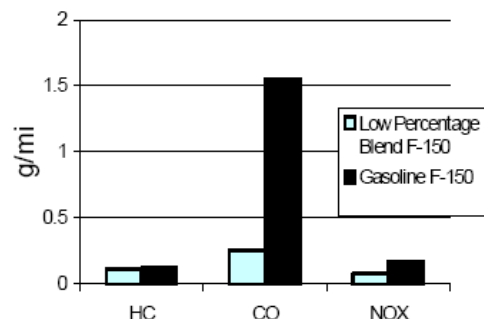

**Figure 8: Emissions Reductions on a Ford F-150**

	<i>CO</i>	<i>NO<sub>x</sub></i>	<i>CO<sub>2</sub></i>
<b><i>Blended Fuel</i></b>	0.255 g/mile	0.077 g/mile	439.25 g/mile
<b><i>Gasoline</i></b>	1.551 g/mile	0.1665 g/mile	621.86 g/mile
<b><i>Net Reduction per day per vehicle</i></b>	52 g	3.6 kg	7.32 kg
<b><i>Percent Reduction</i></b>	84%	54%	30%

**Table 22 Summary of Emissions Reductions Experienced by Blended Fuel<sup>(30)</sup>**

The testing performed on the Ford F-150 included both the IM-240 test and the FTP-75 test. The IM-240 test is used by several states and measures emissions over four minutes, at an average speed of about 30 MPH and a top speed of about 59 MPH. While the FTP-75 test runs for over 30 minutes and at an average speed of about 21 MPH over 11 miles. The Arizona researchers believe the FTP-75 procedure is more accurate, since it takes into account both a cold starting and hot-starting the engine, while the IM-240 test includes only a hot-started engine. Because of this, the IM-240 test undercounts the emissions an engine releases during a cold start. The results above were for the FTP-75 test<sup>(30)</sup>.

## 5.2 Noise Reduction

An important design consideration was to incorporate components that would not be large producers of noise. For this reason, fuel cells which operate in silently were selected as the power generators.

Considering the airport as a whole, two major sources of noise pollution exist, airplanes and ground support equipment. Because the airport does not have control of the noise produced by airplanes, they are forced to mitigate the effects of noise through purchasing surrounding land or

insulating homes. Further, the airport does not own the ground vehicles that continuously handle the baggage throughout the day (owned by the airlines). A current technology that is gaining popularity, nationwide, is the use of electric ground vehicles. To encourage airlines at CAE to make the conversion to electric vehicles, Blue Sky Energy Solutions has added one *eTec SuperCharge*<sup>™</sup> GSE-200DP<sup>(22)</sup>. This charger specifically designed for airport ground support electric vehicles and will provide the capability of switching to electric ground support vehicles.

### 5.3 Water Quality

Water quality at airports is largely influenced by chemicals and fuels used. Introducing an alternative fuel will help reduce the opportunity for fuel leaks. Though this is a small improvement in the present, the system will allow for airport personnel to gain comfort with the fueling process required for a compressed gas. Additionally, the trees that will be used for carbon sequestering will improve water quality by managing storm water flow and acting as natural filters. AmericanForest.Org noted that, “Their canopies, trunks, roots, and associated soil and other natural elements of the landscape filter polluted particulate matter out of the flow toward the storm sewers.”

### 5.4 Energy Efficiency

To determine the efficiency of the system, the energy in and usable energy out are accounted for. The used reformer has an approximate efficiency of 80% (based on Higher Heating Value) while the fuel cells have an approximate efficiency of 46%. The net system efficiency is lowered due to the parasitic losses experienced in the use of multiple compressors. The maximum system power requirement will occur during dispensing and the minimal requirement occur when there is no dispensing or hydrogen storage. The table below details the system efficiency.

<i>Power In</i>		<i>Parasitic Losses</i>		<i>Power Out</i>	
Natural Gas Mass Flow	38.4 kg/h (1873 scfh)	Reformer	30 kW	Fuel Cell Power	150 kW
Unit Energy	42900 kJ/kg (950 BTU/scf)	Natural Gas Compressor	10.2 kW	Hythane <sup>®</sup>	4.21 kg/h
		Hydrogen Compressor <sup>*</sup>	5 kW	Unit Energy	44950 kJ/kg
		Hythane Compressor <sup>*</sup>	37.2 kW		
Total	459 kW		40.2-82.4 kW	Total	202.5 kW
<b>NET SYSTEM EFFICIENCY</b>			<b>38%-40%</b>		

**Table 23: Energy Efficiency**

\* These components do not run all the time therefore a range of efficiency is given.

## 6.0 Marketing and Education

To successfully implement hydrogen technology at Columbia Metropolitan Airport, travelers, employees, and surrounding residents must have a positive perception of its use. Though the current goal of Blue Sky Energy Solutions is to improve the environmental quality at CAE, the movement towards the hydrogen economy will require businesses and citizens of communities nationwide to appreciate the benefits of hydrogen technology. To promote public acceptance of CAE's use of hydrogen technology, the following goals must be accomplished

- 1) To inform the public of the current environmental status of the airport
- 2) To explain the benefits of the system
  - a. Decrease the dependence on foreign oil
  - b. Reduce harmful emissions
  - c. Improve water quality
  - d. Reduce noise
- 3) To explain what Hythane<sup>®</sup> is and the concept of "Bridging the Gap"
- 4) To allay public safety fears

## 6.1 Implementation

### 6.1.1 CAE Traveler Questionnaire

Because technology and its education are changing at a rapid rate, it is important to gain an understanding to how travelers feel about hydrogen technology. Gaining an understanding to how the travelers feel about hydrogen technology and its safety will allow for a custom marketing plan to be implemented. A voluntary questionnaire will be administered two months before the system is built on-site. The traveler will be asked to comment on their feelings about the use of hydrogen at the airport for electrical power production and as an alternative fuel. Aside from free-response questions, a series of true/false and multiple choice questions will be asked allow for the administration to determine what travelers know about hydrogen technology. The questionnaire will be designed to only require five minutes of the travelers' time. Once the results are tabulated, an adaptive marketing and education plan can be implemented which will target the concerns listed in the questionnaire.

### 6.1.2 On-site Marketing and Education

The education for the hydrogen technologies being used at CAE will begin at the airport. Various tools will be used to alleviate traveler concerns defined in the questionnaire. Pamphlets and educational brochures will be available at the terminal gates for travelers to read while waiting for their flights. Additionally, an LCD monitor display will be strategically placed near the food court which will play a video that includes information on the system capabilities, the Hythane<sup>®</sup> vehicle fleet, the environmental benefits, and the safety precautions in place. Posters will be placed at various locations in the terminal to market the benefits of the design.

#### 6.1.2.1 Shuttle Bus Marketing

Because the shuttle services are not owned by the airport, the conversion of these vehicles to run on an alternative fuel was not within the scope of the proposal. It is the hope of Blue Sky Energy Solutions that once the re-fueling infrastructure is in place, the shuttle companies will convert

their fleet to an alternative fuel. Because shuttles are seen by most travelers, they offer a great opportunity to advertise the system in place at the airport. If the shuttles are converted to run on the alternative fuel, a real-time example of the advertisement will be present and the shuttle can be marked, indicating that Hythane<sup>®</sup> that is being used. If the shuttle companies do not comply, a request will be made to market the hydrogen system within the bus on a poster that will be visible to travelers.

### **6.1.3 Off-site Marketing and Education**

Total public acceptance is imperative for the design. To gain this acceptance, various activities will be planned including:

- Press Release
- Town Meeting
- Elementary, Middle, and High School Visits
- Driving of Hythane<sup>®</sup> vehicles in local parades

During all events, it will be useful to show that the Federal Aviation Administration (FAA) supports the efforts to clean the environment at CAE. If possible, an FAA representative will be asked to make a comment regarding the importance of the hydrogen system in place. Also, the Fire Marshall will be asked to comment on the safety precautions taken for the design. With these people's permission, the comments will then be used in various press releases, pamphlets and brochures.

## **6.2 Future Commitment**

To show support of hydrogen technology research and educational efforts, CAE will sponsor two \$1,000 scholarships for graduating high school seniors in South Carolina. Students will be asked to write about the importance of alternative energy and fuels while indicating their interest in pursuing a career in this field. It is important for the youth to know that they will be key players in the future of the hydrogen economy.

## **6.3 Project Management**

To promote the involvement of local students, business and marketing colleges at universities in South Carolina will be asked if they are interested in offering a group of students the opportunity to manage the marketing and education for this project for a set period of time. This can be done as a paid internship or a class project. When students have a sense of ownership in a project, they will grow to become more passionate about the subject at hand.

*Columbia Metropolitan*  
*Airport*  
 is  
*Bridging the Gap*  
 to the



*Economy*

PAST



PRESENT



FUTURE



Columbia Airport is serving as a *model* for airports nationwide with the implementation of hydrogen technology.

*Features Include:*

- ❖ *Hythane<sup>®</sup> Vehicle Fleet*
- ❖ *Electrical Power Production Using Fuel Cells*

*Join Us in the Movement*

*Solution Provided By*



## Appendix

### Calculation for the Hythane<sup>®</sup> required per vehicle

#### Properties Used for Calculations

$$\text{Hythane Density} = .8 \times \text{Density Methane} + .2 \times \text{Density Hydrogen}$$

$$\text{Adjusted fuel economy} = 13 \text{ mpg} \times (1 - .3) = 9 \text{ mpg}$$

$$\text{Total Energy Stored per 25 gallon tanks} = 42.5 \frac{\text{MJ}}{\text{kg}} \times 737 \frac{\text{kg}}{\text{m}^3} \times 25 \text{ gal} \times \frac{1 \text{ m}^3}{264.17 \text{ gal}} = 2964 \text{ MJ}$$

#### Gasoline Use per Day

$$\text{Gasoline required per vehicle per day} = \frac{20 \text{ mph}}{9 \text{ mpg}} \times \frac{2 \text{ hours}}{1 \text{ day}} = 4.4 \text{ gallon per day}$$

$$\text{Energy required per vehicle per day} = 4.4 \text{ gal} \times \frac{1 \text{ m}^3}{264.17 \text{ gal}} \times 31323 \frac{\text{MJ}}{\text{m}^3} = 521.2 \text{ MJ}$$

#### Available Hythane<sup>®</sup> Storage per Tank

$$\text{Available storage for Hythane per vehicle} = 110 \text{ L} \times \frac{\text{m}^3}{1000 \text{ L}} \times 153 \frac{\text{kg}}{\text{m}^3} = 16.8 \text{ kg}$$

$$\text{Usable Hythane per vehicle} = 16.8 \text{ kg} - 6 \frac{\text{kg}}{\text{m}^3} \times .11 \text{ m}^3 = 16.2 \text{ kg}$$

$$\text{Usable Hythane energy per vehicle} = 16.2 \text{ kg} \times 40.28 \frac{\text{MJ}}{\text{kg}} = 651.4 \text{ MJ}$$

### Electrical Requirements

The selection of both transformers is made by calculating the apparent power consumed by the load. The apparent power is measure in kilovolts-amperes (kVA). For single phase the kVA is calculated by <sup>(24)</sup>.

$$kVA = \frac{v \times i}{1000}$$

For three phases the kVA is calculated by

$$kVA = \frac{v \times i \times \sqrt{3}}{1000}$$

Where  $\sqrt{3}$  or 1.732 is the ratio between the voltage line to line and voltage line to neutral and v is the voltage. Other important issue in AC power is the ratio between the real power (KW) and the apparent power (kVA). This is known as Power Factor (PF). A high PF is a good indicator of how efficient the current is being converted into useful work. For purposes of our calculations, a power factor of 0.85 is used.

Other electrical requirements such as voltage, number of phases and power were obtain from the specification sheets of each component. One more value had to be calculated, this is the amperage. For single phase the amperage (i) is calculated by

$$i = \frac{kW \times 10003}{v \times PF}$$

For three phases systems

$$i = \frac{kW \times 10003}{v \times PF \times \sqrt{3}}$$

Component	Voltage (V <sub>ac</sub> )	Amp (I)	Phases	Power (kW)	KVA
Hythane Blender HX500	120	1.961	1	0.17	0.2
Deionizer	120	1.765	1	0.18	0.21
Hydrogen generator Adéo-100 TM - Aux	120	0.686	1	0.07	0.082
Cooling Tower ACT 100	208	7.184	3	2.2	2.588
Compressor 1 – Natural Gas	208	18.157	3	5.56	6.541
Compressor 2 – Hydrogen	208	44.151	3	13.52	15.906
Adéo-100 TM – Main Power	480	42.453	3	30	35.294
Compressor 3 – NG	480	52.642	3	37.2	43.764
Super Charge TM GSE-200DP	480	21.226	3	15	17.647

### Vehicle Refueling Analysis

An analysis based on mass conservation and the mass flow equation described in section 2.6.2 was performed to define the pressure vs. time curve for a vehicle tank. Based on assumed pressure values in each tank and the known minimum vehicle pressure, the mass of Hythane ® transferred was determined using the ideal gas law. Next, using the mass flow rate was determined based on the Mach number and tank pressure. Finally, the inverse of the mass flow rate was multiplied by the mass transferred to determine the time required to for each cascade tank to pressurize the vehicle tank.

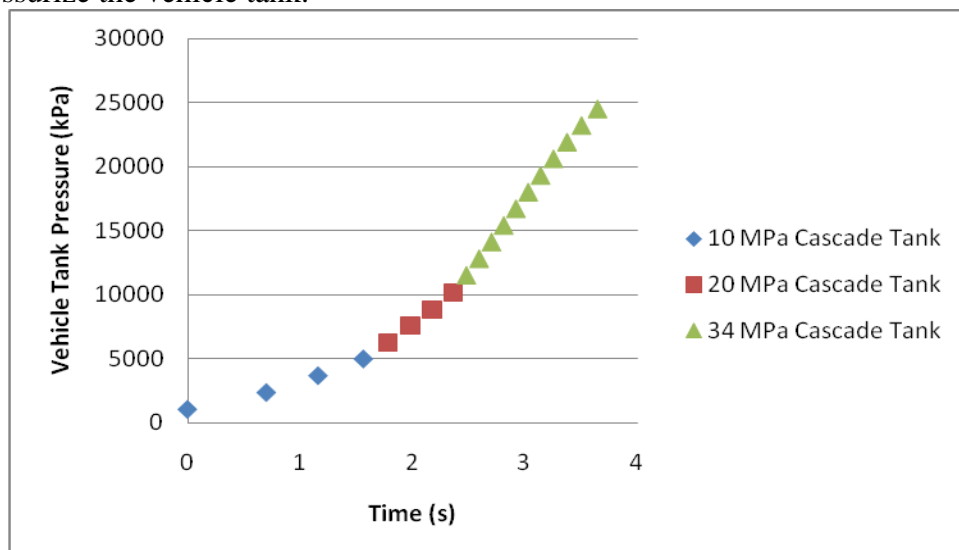

**Design Layout**

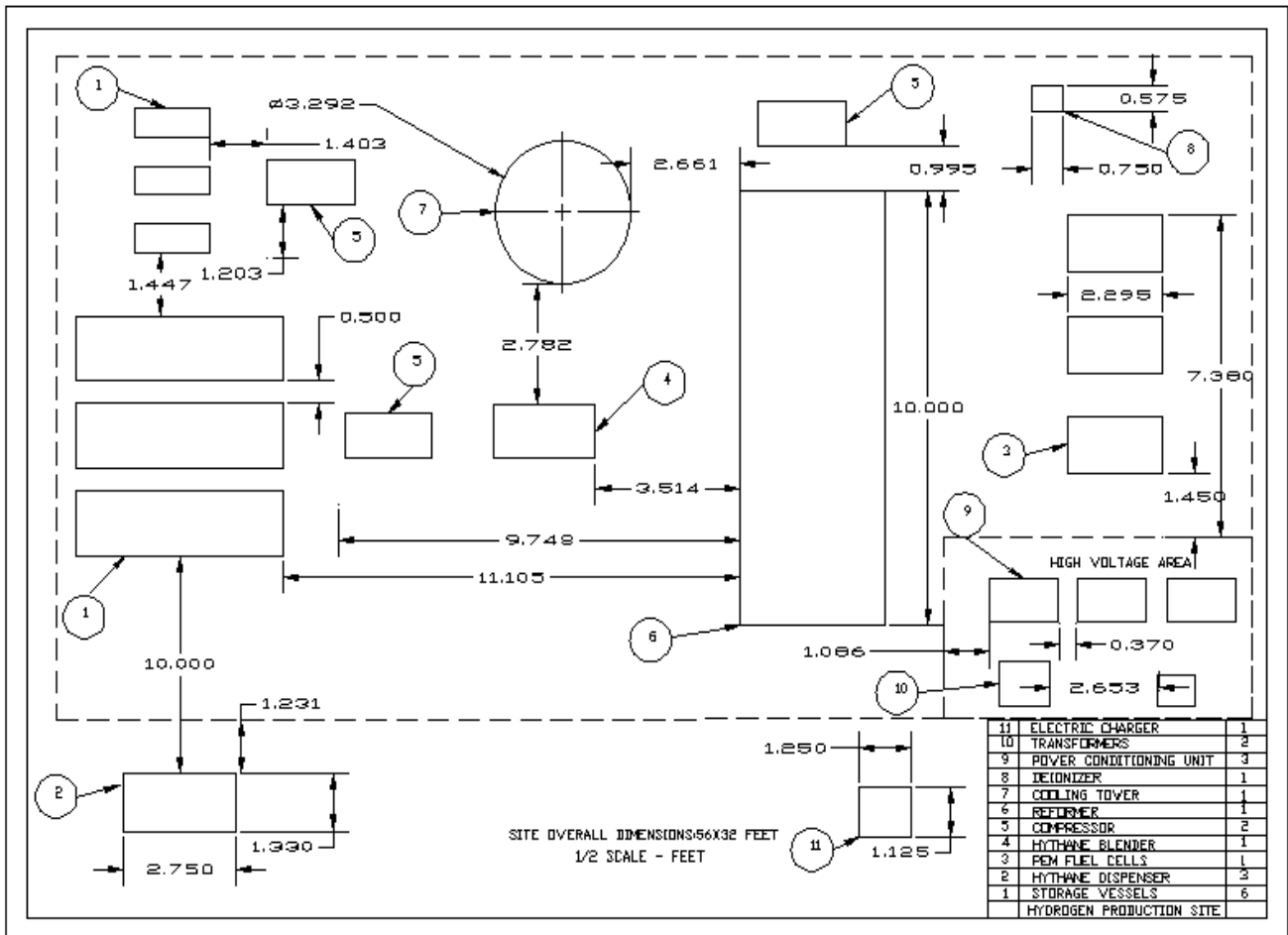
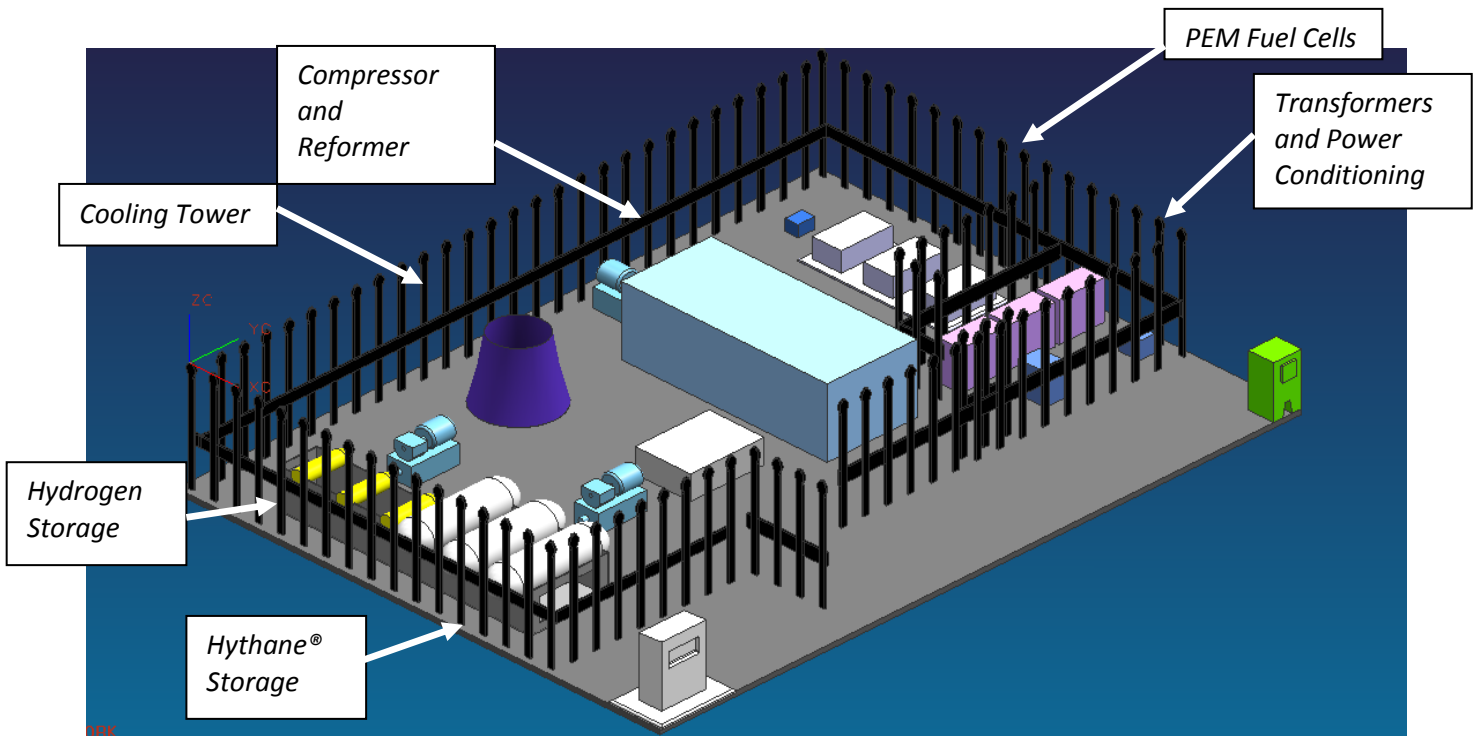

### Design/Process Failure Modes and Effects Analysis

Item	Function	Potential Effect(s) of failure	Severity	Potential Cause(s)/ Mechanism(s) of Failure	Comments	Occurrence	Current Design Controls		RPN
							Detection	- Prevention	
								- Detection	
HyRadix Adeo 100 Auto thermal Reformer	Generates 215 kg of H <sub>2</sub> gas per day with 99.95% purity	Differential pressure between reformer and outlet greater than 5 psi, possible H <sub>2</sub> leakage	4	Leakage from the reformer vessel and/or outlet seal	Complies with NFPA 497 & ICE 60079-10	1	Install pressure sensors to monitor outlet and vessel pressures, PLC to shut off reformer, feed NG, and DI water into reformer. Warning to the Human-machine interface (HMI). Install LEL detectors to monitor for the presence of H <sub>2</sub> .	3	12
	Interfaces with the cooling tower water to maintain a maximum operating temperature of 100 F	Reformer overheats	6	Damage to the reformer vessel, possible leakage	Normal operating temperature for reformer is 75-100 F	1	Temperature sensors to detect and monitor reformer temperature; when temperature exceeds 110 F, PLC shuts off NG flow from feed compressor and DI water flow.	5	30
Compress or for Reformer/ blender	Increase the pressure of the natural gas from the utility pressure (~25 psi) to 145 psi	Failure of compressor: motor failure, seal failure, internal compressor failure	6	damage to piping or compressor	max operating pressure is 170 psi	1	Maxon blocking valve before the compressor. Install a regulator. Pressure gauge will monitor high pressure.	2	12
	Interfaces with the natural gas utility supply piping and feeds both the blender and reformer	utility feed pressure too low	6	compressor cannot increase pressure to meet reformer requirements	Power Supply at motor interface	1	Maxon shut off valve before the compressor. Install a regulator. Pressure gauge will monitor low pressure.	2	12
Cooling tower	Provides re-circulated water at 85 F at a flow rate of 110-125 gpm. Interfaces with the reformer. Cooling water recirculation system to include the following to control bacteria counts: UV light in the piping feeding the reformer and a biocide supply system	Cooling tower water flow less than 110 gpm or no water flow, reformer overheats	6	Pump motor damage or failure	Motor wiring to conform to NEC standards	3	Ammeter measuring current draw interfaced to PLC. Warning from PLC to HMI when current draw drops below 85 percent of set point. PLC shuts NG utility feed valve and reformer	3	54
			5	Leakage within the cooling tower water supply piping and/or pump leak		3	Level sensor connected to PLC for warning and alarm of out of range level. Pressure gauges and flow meters installed in water supply and return piping. PLC to warn HMI if flow rate or pressure drop to over 90% of set points. PLC to shut off reformer and NG gas feed into reformer.	3	45
		cooling tower water has high bacteria count	6	UV light failure		7	Periodic manual inspection of UV light bulb. PLC to monitor bulb's operating duration. PLC to warn HMI if bulb life has surpassed 110% of bulb life rating.	4	168
DI water system	Removes cat ions and anions from city water. Interfaces with reformer and PEM fuel cells	DI water conductivity over 0.5 micromhos	4	Potential damage to the PEM membranes	DI water conductivity less than 0.5 micromhos	3	Install conductivity gauges to the DI feed piping, PLC to warn HMI when conductivity exceeds 0.4 micromhos. PLC shuts off the PEM fuel cells	2	24
	DI water flow rate to PEM cells is 360 slpm. DI water flow to reformer is 0.5 slpm.	DI water flow less than the required flow rates	6	Pump motor damage or failure	Motor wiring to conform to NEC standards	3	Ammeter measuring current draw interfaced to PLC. Warning from PLC to HMI when current draw drops below 85 percent of set point. PLC shuts off PEM fuel cells, reformer, NG feed valves to reformer and H <sub>2</sub> feed valves to PEM cells	3	54
			5	Leakage within the DI supply piping and/or pump leak		3	Pressure gauges and flow meters installed in DI water supply piping. PLC to warn HMI if flow rate or pressure drop to over 90% of set points. PLC to shut off PEM fuel cells, reformer, NG gas feed into reformer.	3	45
Power conditioner	Convert PEM Fuel cell DC current to 480 VAC, 3-phase electrical energy	electrical voltage or current not to specification	6	Potential damage to the sub-station	Power Conditioning system to conform to NEC standards	4	install a metering system and a fuse/circuit breaker system before and after the power conditioning system	2	48



## References

1. Larminie, James, and Andrew Dicks. Fuel Cell Systems Explained. 2nd ed. Chichester: John Wiley & Sons, Inc, 2003.  
*Describes PEMFC technology and used to calculate hydrogen fuel rate.*
2. "Estimated Cost." 2007. NedStack. 1 Oct. 2007 <from [www.nedstack.com/content/products.html2](http://www.nedstack.com/content/products.html2)>.  
*Found cost of \$/kW.*
3. "Nedstack PS50 Production Specification" 2007. NedStack. 1 Oct. 2007 <from [www.nedstack.com/content/ps50.pdf](http://www.nedstack.com/content/ps50.pdf) > .  
*Found fuel cell specifications.*
4. "ABB Power Conditioning Systems." 2007. ABB. < from [http://library.abb.com/GLOBAL/SCOT/scot232.nsf/VerityDisplay/9E0B36878D4CA790C1256DF8005FFDC9/\\$File/PRS%20Hydrogenics.pdf](http://library.abb.com/GLOBAL/SCOT/scot232.nsf/VerityDisplay/9E0B36878D4CA790C1256DF8005FFDC9/$File/PRS%20Hydrogenics.pdf)>.  
*Power conditioning*
5. EG&G Technical Services,. Fuel Cell Handbook. 7th ed. U.S. Department of Energy Office of Fossil Energy, 2004.  
*Describes Fuel cell calculations*
6. Cengel, Yunus A., and Michael A. Boles. Thermodynamics - an Engineering Approach. 5th ed. New York: McGraw Hill, 2006.  
*Found molar masses, densities and Enthalpy of formation values.*
7. Edwards, T, J Williams, F Lynch, M Frailey, G Dixon, S Wayne, and R Nine. Hydrogen Blended Natural Gas Operation of Heavy Duty Turbocharged Lean Burn Spark Ignition. SAE International. 2004. 1-15.
8. US Department of Energy FreedomCAR Low-Percentage Hydrogen/CNG Blend Ford F-250 Operating Summary, January 2003
9. "About Hythane." Hythane. 2007. 30 Sept. 2007 <<http://www.hythane.com/>>.
10. "Carbon Calculator." 2006. Savannah Supplies Incorporated. 20 Oct. 2007 <[http://www.savannah-supplies.com/index.php?target=pages&page\\_id=CarbonCalculator](http://www.savannah-supplies.com/index.php?target=pages&page_id=CarbonCalculator)>.

11. "Electricity Generation." CNN. 20 Oct. 2007  
<<http://www.rdono.com/SPECIALS/2006/fueling.america/interactive/popup.electric/us.map.electric.swf>>.
12. Alternatives to Traditional Transportation Fuels 1994. Energy Information Association. 25 Sept. 2007 <<http://www.eia.doe.gov/cneaf/alternate/page/environment/exec2.html>>.
13. "Go Zero Frequently Asked Questions." The Conservation Fund. 2007. 7 Nov. 2007  
<<http://www.conservationfund.org/gozero/faqs>>.
14. "Stationary Fuel Cell PCS." SatCon Technology Corporation. 2005. 15 Nov. 2007  
<<http://www.satcon.com/power/altenergy/fuelcell.php>>.
15. "SatCon PowerGate 50 KW 480/3 Inverter with Combiner." Affordable Solar Group, LLC. 2007. 15 Nov. 2007 <<http://www.affordable-solar.com/satcon.ae.50.60.pv.a.g.c.htm>>.
16. McPartland, Brain J. National Electrical Code Handbook (25th Edition). Blacklick, OH, USA: McGraw-Hill Professional, 2005. 16 Nov. 2007  
<<http://site.ebrary.com/lib/wayne/Doc?id=10085471&ppg=1093>>
17. "Spec Sheet - Transformer: Primary 480V-Delta, Secondary 208Y/120 V 3phases, 60 Hz." Jefferson Electric, Inc. 16 Nov. 2007 <<http://www.jeffersonelectric.com/cgi-bin/site.pl?12201&id=423-7194-000&query=423-7194-000>>
18. "Spec Sheet - Transformer: Primary 480V-Delta, Secondary 480Y/277V - 3 Phases, 60Hz." Jefferson Electric, Inc. 16 Nov. 2007 <<http://www.jeffersonelectric.com/cgi-bin/site.pl?12201&id=423-7255-000&query=423-7255-000>>
19. "3 Ph dry type transformers." Fox Electric Supply Company. 16 Nov. 2007  
<<http://www.foxelectricsupply.com/content/products/ProductCatalog.asp?qscategoryId=26413/>>.
20. "Fluitron Inc." GlobalSpec. 28 Oct. 2007 <<http://process-equipment.globalspec.com/SpecSearch/MatchingProducts?Comp=1594&QID=9885878&VID=151048>>.
21. "Tuffshell Fuel Tanks." Lincoln Composites. 1 Nov. 2007  
<<http://www.lincolncomposites.com/media/LC%20Space%20Age%20PI.pdf>>.
22. "GSE-200DP FAST CHARGER." ETec. 17 Oct. 2007  
<[http://www.etecevs.com/pdf/supercharge\\_gse-200dp\\_brochure.pdf](http://www.etecevs.com/pdf/supercharge_gse-200dp_brochure.pdf)>.

---

23. "CNG Natural Gas Compressor Packages." P.C. McKenzie Company. P.C. McKenzie Company. 10 Nov. 2007 <[http://www.mckenziecorp.com/compression\\_packages.htm](http://www.mckenziecorp.com/compression_packages.htm)>.
24. "Power Factor." L M Photonics. 20 Nov. 2007 <<http://www.lmphotronics.com/pwrfact.htm>>

25. Voluntary Airport Low Emissions Program. Federal Aviation Administration. Office of Airports Airport Planning and Programming, 2007. 4 Nov. 2007  
<[http://www.faa.gov/airports\\_airtraffic/airports/environmental/vale/media/vale\\_techrep\\_v4.pdf](http://www.faa.gov/airports_airtraffic/airports/environmental/vale/media/vale_techrep_v4.pdf)>.
26. Ueno, K., R. E. Bye, and K. S. Hunter. Compressor Efficiency Definitions. University of Colorado, VAIREX Corporation. 2003. 11-14. 4 Nov. 2007  
<<http://www.vairex.com/pdf/Efficiency-0523.pdf>>.
27. "High Voltage Training Course." HVM Corporation. 25 Nov. 2007  
<[http://www.hvmcorp.com/Documents/Training%20Service%20Line%20Card\\_HVM\\_5.2005.pdf](http://www.hvmcorp.com/Documents/Training%20Service%20Line%20Card_HVM_5.2005.pdf)>
28. Munson, Bruce R., Donald F. Young, and Theodore H. Okiishi. Fundamentals of Fluid Mechanics. 5th ed. Hoboken: John Wiley & Sons, Inc, 2006. 329-330.
29. "CASCADE Version 3.0 User's Manual." Gas Technology Institute. 10 Nov. 2007  
<<http://www.interenergysoftware.com/PDF/CasManual.pdf>>.
30. Kremer, Janet. Modeling Emissions Factors for Compressed Natural Gas Vehicles. Office of Mobile Services - U.S. Environmental Protection Agency. 1999. 12 Nov. 2007  
<<http://www.epa.gov/otaq/models/mobile6/m6ful004.pdf>>.